



Driven By Innovation

Smart Entrance Solutions



- 03 About Us**
- 04 Flap Barrier**
 - 06 Product Range
 - 07 Technical Specification
 - 07 Functions & Features
- 08 Swing Barrier**
 - 10 Product Range
 - 11 Technical Specification
 - 11 Functions & Features
 - 12 P Type Swing Barrier
- 14 Sliding Barrier**
 - 16 Product Range
 - 17 Technical Specification
 - 17 Functions & Features
- 18 Tripod Turnstile**
 - 20 Product Range
 - 21 Technical Specification
 - 21 Functions & Features
- 22 Single Drop Arm Turnstile**
 - 23 Features & Technical Specification
- 24 Full Height Turnstile**
 - 26 Product Range
 - 27 Technical Specification
 - 27 Functions & Features
- 28 Boom Barrier**
 - 30 Product Range
 - 31 Technical Specification
 - 32 Special Application Boom Barrier
- 34 Application**
- 38 Other VAS Product Range**
- 39 Avians Advantage**



About Us

Avians is headquartered in one of the most renowned Pune's industrial and Automotive hub and has its own infrastructure and manufacturing capabilities in area of more than 2,80,000 sq ft. with state of the art technologically advanced plant and in-house warehouse facility with a team of experts.

Avians is an **ISO:9001, ISO:14001 and ISO:45001** company with its complete range from to its latest range of Physical Access Solutions,

which are truly tested for Indian conditions and have been certified with CE for the complete array of products in Physical Access Systems (PAS).

Avians offers wide range of products from **Turnstile, Flap Barrier, Swing Barrier, Boom Barrier, Bollards, Road Blocker, Tyre Killer, Underground Vehicle Scanning System, Crash Rated Gates, Gate-Door-Rolling Shutter Motors to Access Control Solution**. These products are designed to create a difference to your secure premises and assures peace of mind to users.

The company's strong technical backbone in innovative R&D and manufacturing facilities ensures that each product delivers on our promise of quality, precision and innovation. The company's extensive Pan India sales and service network presence makes sure support is always at hand.

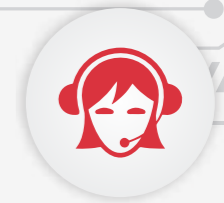

Customer Care



CE Certified Range



Technical Expertise



38+ Years Legacy



Innovation Driven Company



Top Class Infrastructure & Manufacturing Capabilities



Driven By Innovation
Smart Entrance Solutions



Flap Barrier

CE

Flap Barrier

DRIVEN BY INNOVATION

Flap Barriers are well adopted in entrances and exits of offices or construction sites, to help to track staffs and visitors, only authorized users are able to access to specific areas through the Flap Barriers. This Flap barrier is available as a single- or multiple-lane setup and is compatible with most access control systems, such as, Biometric and Proximity Readers. The Flap Barrier combine features like high throughput rate, user acceptance, comfort, attractive design and different levels of security to prevent unauthorized access pedestrian safety has also been taken into account.



RFID/ Finger Print Option



IP55



DC Motor Drive

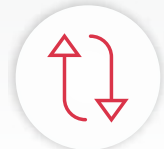

2 Way Passage Directions



SS304



High Performance Motor



Provision To Integrate Access Control System



Anti Passback & Anti Tailgating Sensors For Safety



Elegant & Slim Design

Product Range



Pro

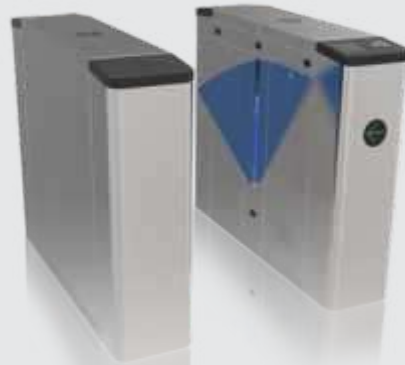

Pro+



Prime

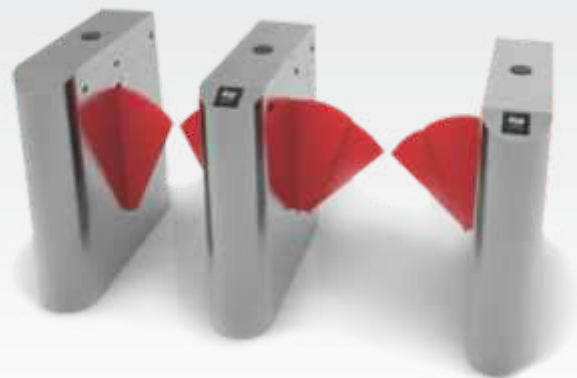

Pro+ Wide

Options

- Single lane or multiple lane setups.
- Normally open or closed working mode.
- Top cover equipped with artificial marble or stainless steel, several color of arms optional. Adaptation for integration of a proximity card reader under the top cover.
- Pedestal for mounting of external card readers, Biometric or other authorization systems.



Single Core



Dual Core

Technical Specification

Flap Barrier Single/Dual Unit				
Model	Pro	Pro+	Prime	Pro+ Wide
Dimension (LxWxH) mm	1200 x 280 x 960	1200 x 280 x 980	1410 x 300 x 1005	1200 x 300 x 980
Passage width	550 mm	550 mm	550 mm	600/900 mm
Material thickness	1.0 mm SS304	1.2 mm SS304	1.2 mm thick SS304	1.2 mm SS304
Flap thickness	10 mm	10 mm	15 mm	50 mm
Power supply	230 VAC	230 VAC	230 VAC	230 VAC
Protection rating	IP 55	IP 55	IP 55	IP 55
Arm type	Polycarbonate	Polycarbonate	Transparent PC + LED light	Polycarbonate with leatherette cover
Operating time	0.2 Sec	0.2 Sec	0.2 Sec	0.2 Sec
Throughput rate p/m	30-35	30-35	30-35	30-35
Motor	DC motor	DC motor	Fully automatic servo motor	DC motor
Body structure	Standard design	Sturdy design	Premium elegant & slim design	Sturdy design
Access control integration	Provision of integration of single access control accessories	Provision of integration of multiple access control accessories	Provision of integration of single access control accessories	Provision of integration of single access control accessories
LED indication	LED indication arrows for lane indication	LED indication arrows for lane indication	LED indication arrows for access indication	LED indication arrows for access indication
			LED lights on flaps Top cover with multi color indication LED on front edges	
Wide lane	NA	NA	Optional	Standard

Functions & Features

- Bi-direction/ can set to one direction & one for free.
- Direction indication LED lights on the barrier to indicate access status.
- High performance DC Motor.
- Only one person will pass with one card/anti-tailgating feature.
- Sound alarm Indication feature preventing illegal entry or exit.
- Can adjust the operation speed of the barrier according to the flow of passengers to improve the passing rate.
- Integration with various access control system like, biometric, card, QR/barcode & face recognition terminals.
- With standard fire alarm input interface, when received the fire alarm signal flaps will get open automatically without any conditions (optional).
- Installed in Indoor or outdoor with canopy.

ACCESSORIES

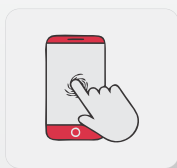

Smart Phone Based Access

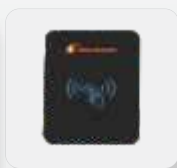

RFID Reader



Biometric Access Control



Face Recognition

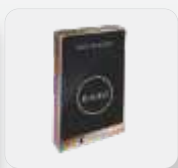

QR Code Reader

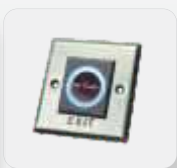

Touchless Sensor



Push Button



Driven By Innovation
Smart Entrance Solutions

A photograph of a modern office lobby featuring three sleek, silver swing barriers with black tops. The barriers are arranged in a line, and the background shows a contemporary interior with a reception desk, potted plants, and glass partitions. A large blue diagonal graphic element is overlaid on the bottom right of the image.

Swing Barrier

DRIVEN BY INNOVATION

CE

Swing Barrier

DRIVEN BY INNOVATION

Avians Swing Barrier series designed for smooth and silent operation and draws very less power. It's made of stainless steel which makes it highly durable.

These are normally held in a locked position, thus denying access to the secured side. On Swing Barrier Reader (RFID) Positively Recognises a user's valid Access Card or Fingerprint & Barriers swing automatically, thus allowing users passage to the secured side.

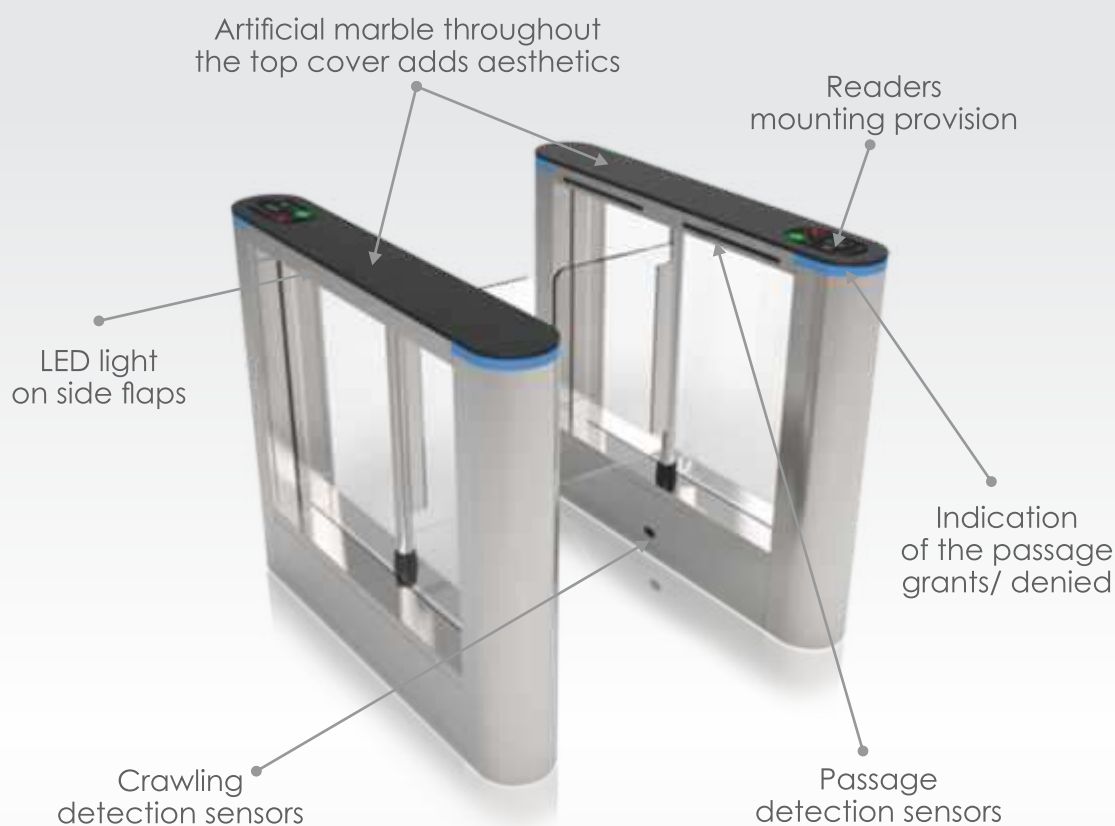

Slim Design



High Throughput with High Protection Level



Complete Automatic Drive System



Alarm System



Communication Mode RS 485



Servo Motor



Infrared Sensors For Safety



Smart Logic Controller



Sturdy Side Flaps Which Adds Value In Design

Product Range



Pro



Pro+



Prime

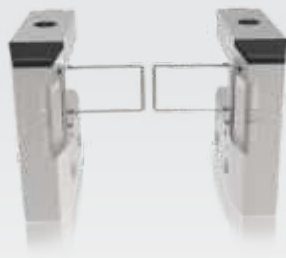

Pro-M



Pro+M



Excellent Finish



Advance Design



Hieroglyphic Symbols

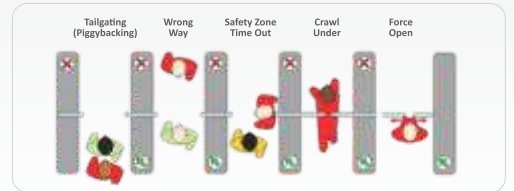

User Safety

Options

- Single lane or multiple lane setups.
- Normally open or closed working mode.
- Top cover equipped with artificial marble or stainless steel several color of arms optional adaptation for integration of a proximity card reader under the top cover.
- Pedestal for mounting of external card readers, biometric or other authorization systems.



Single Core



Dual Core

Technical Specifications					
Swing Barriers Single/Dual Unit					
Model	Pro	Pro+	Prime	Pro M	Pro+ M
Dimension (LxWxH)mm	1400x185x1020	1200x185x980	1410x150x1000	1200x280x960	1200x280x980
Pass width	600 mm	600 mm	600 mm	900/1100 mm	600 mm
Material thickness	1.2 mm S304	1.5 mm SS304	2.0 mm S304	1.0 mm S304	1.2 mm S304
Power supply	230 VAC	230 VAC	230 VAC	230 VAC	230 VAC
Protection rating	IP 55	IP 55	IP 55	IP 55	IP 55
Arm type	Transparent acrylic	Transparent acrylic	Tempered glass	Metallic	Metallic
Side panels	Transparent acrylic	Acrylic+LED light side bar	Transparent acrylic	NA	NA
Operating time	0.2 Sec	0.2 Sec	0.2 Sec	0.2 Sec	0.2 Sec
Throughput rate p/m	30-35	30-35	30-35	30-35	30-35
Motor	DC motor	Fully automatic servo motor	Fully automatic servo motor	DC motor	DC motor
Body structure	Standard design	Sturdy design	Premium elegant & slim design	Standard design	Sturdy design
Top frame	Black artificial marble at access portion	Black artificial marble on top	SS Finish with premium LED indicators	Standard design	Sturdy design
Access control integration provision	YES	YES	YES	YES	YES
Wide lane	Optional	Optional	NO (Full height)	Standard	NO

Functions & Features

- Bi-direction, can set to one direction & one for free.
- Direction indication LED lights on the barrier to indicate access status.
- High performance motor.
- Only one person will pass with one card/ anti-tailgating feature.
- Sound alarm indication feature preventing illegal entry or exit.
- Can adjust the operation speed of the barrier according to the flow of passengers to improve the passing rate.
- Integration with various access control system like, biometric, card, QR/barcode & face recognition terminals.
- With standard fire alarm input interface, when received the fire alarm signal flaps will get open automatically without any conditions.
- Suitable for indoor installation.
- LED lights on side doors of barrier body (optional).
- Flap option available metallic bar or acrylic wings.

ACCESSORIES

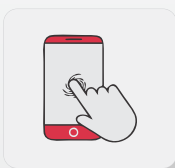

Smart Phone Based Access

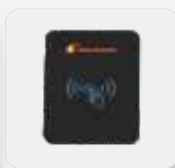

RFID Reader



Biometric Access Control

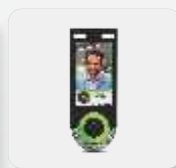

Face Recognition

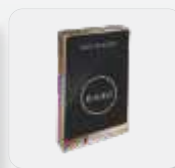

QR Code Reader

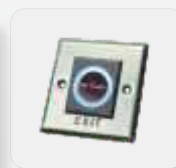

Touchless Sensor

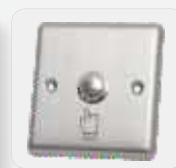

Push Button

P Type Swing Barrier

P Type Swing Barrier is specially designed for the Specially-Abled, Large Package Entry, Individuals with Carts, Trolley Entry etc. It is fully motorized bi-directional gate and can be used in standalone or along with the other physical access control system. Smooth & silent motorized drive mechanism along with safety features ensures high comfort to the user. Its wings swing 90 degree in both the directions. P type barrier allows maximum opening of 900 mm.

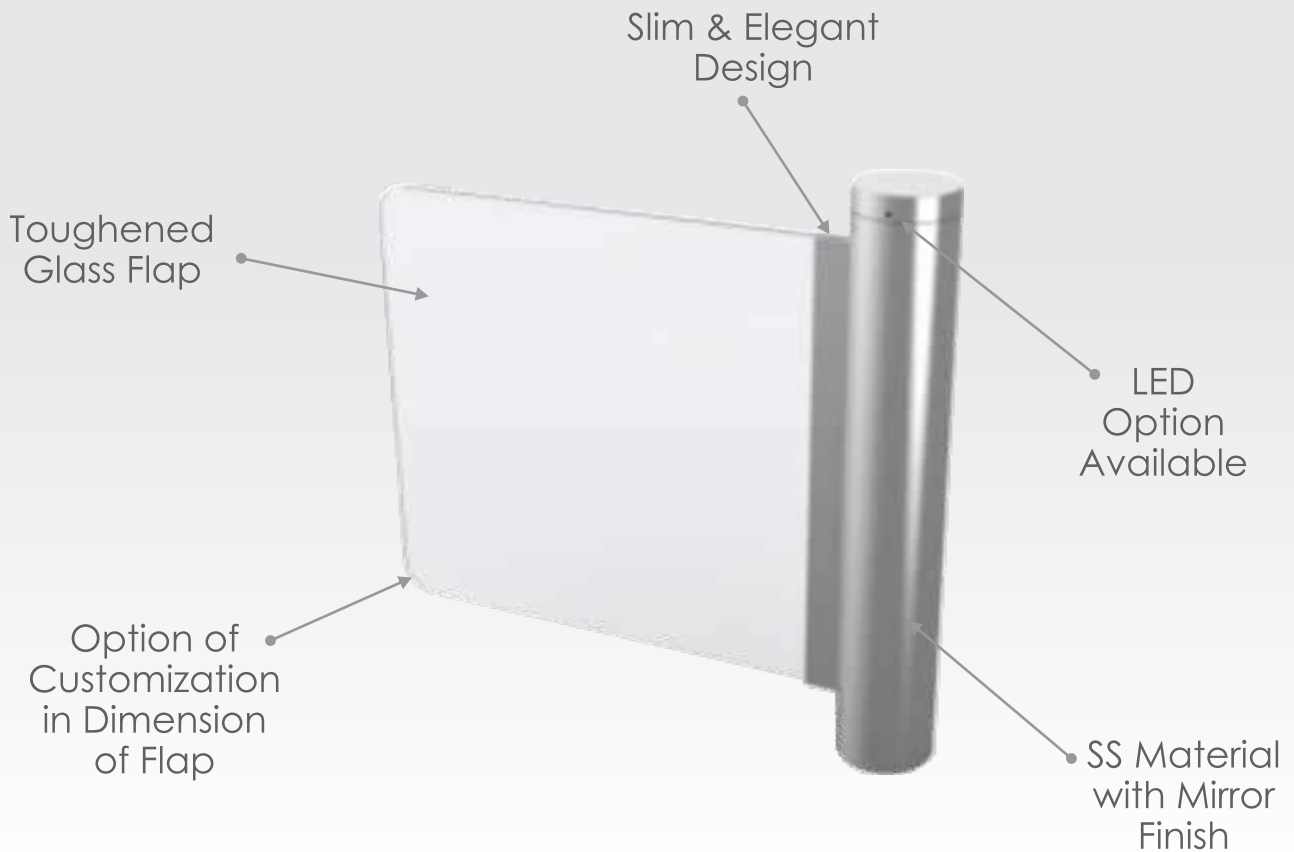

Servo Motor



Smart Logic Controller



Wide Passage Provides Access To Wheel Chair

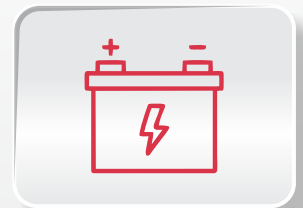

Failure Safe

Features

- Designed for secured & reliable operation.
- Cabinet or central pillar is constructed from stainless steel material.
- Minimal exposed hardware.
- Bi-directional operational control.
- P type swing barrier controlled via micro-controller logic unit.
- Can be integrated with any access control system.

Product Range



Pro Metallic



Pro Acrylic

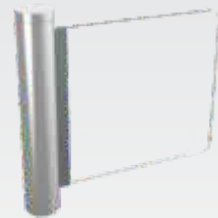

Prime

Technical Specifications		
P Type Swing Barriers		
Model	Pro	Prime
Dimension (LxWxH) mm	200 x 200 x 980	168 x 1000
Passage width	600/900 mm	900/1100 mm
Power supply	230VAC, 35W	230VAC, 35W
Arm type	Metallic/Acrylic	Glass flap
Operating time	0.2 sec	0.2 sec
Protection level	IP55	IP55
Throughput rate p/m	30-35	30-35
Motor	DC Motor	Fully automated servo motor
LED indication	NO	Optional
Emergency exit	Optional	YES



Driven By Innovation
Smart Entrance Solutions

Sliding Barrier

DRIVEN BY INNOVATION

CE

Sliding Barrier

DRIVEN BY INNOVATION

Sliding Barriers are well adopted in entrances and exits of offices, airport, malls, to help to track staffs and visitors, only authorized users are able to access to specific areas through the barriers. Lights on the barriers are to indicate the status of the barrier. Blue LED lights indicate locked barriers. Blinking green lights indicate accessible barriers.

We integrate access control system with the barrier for authoritative access. RFID, Biometric Verification, Face Recognition, are options for Flexible Access Control System. These barriers are installed in conjunction with any access control system & provide valuable assistance to security personnel at any monitored entrance.

The Sliding Barrier combine features like high throughput rate, user acceptance, comfort, attractive design and different levels of security to prevent unauthorized access pedestrian safety has also been taken into account.

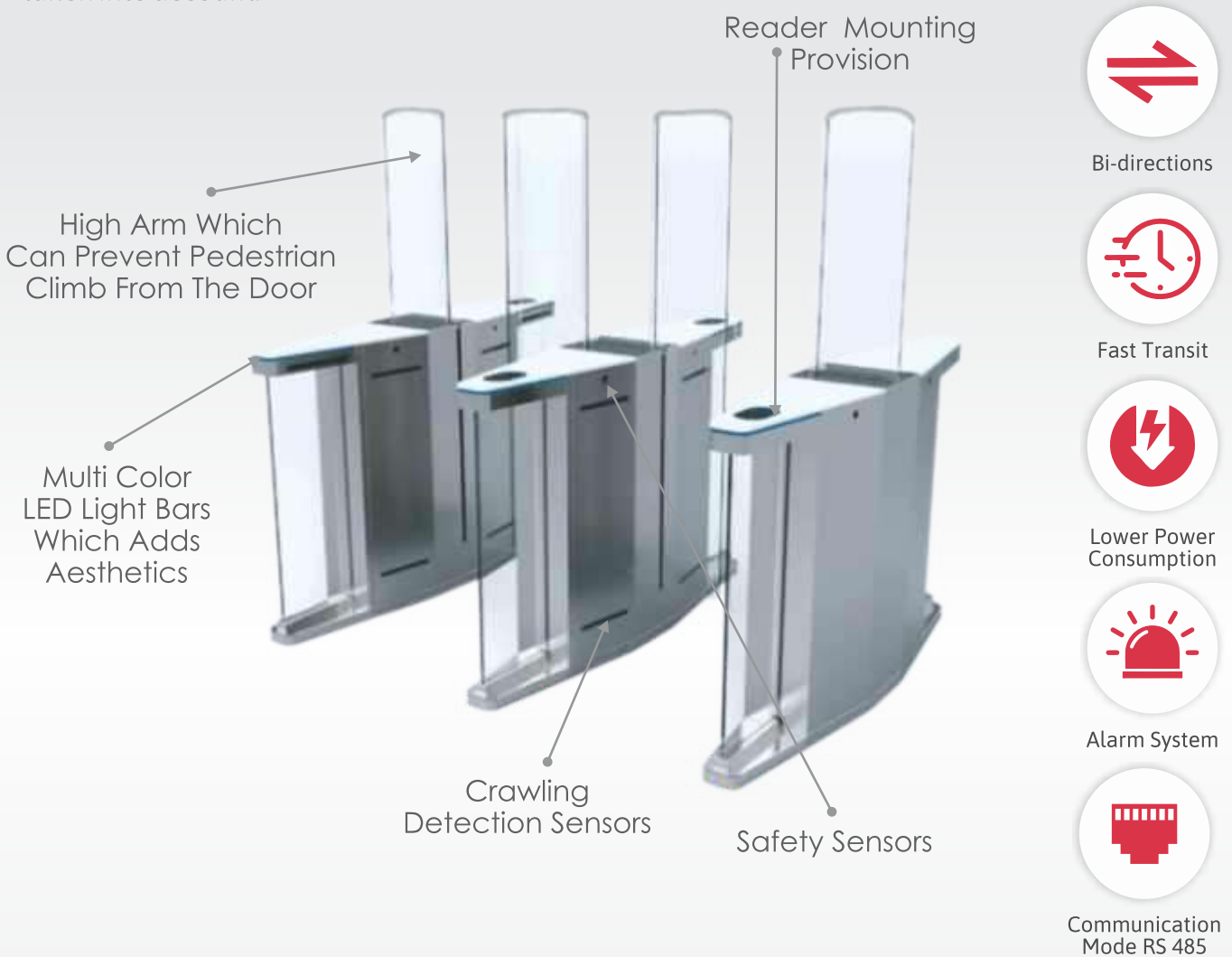

High-End Sliding Gate Machine Core



Infrared Sensors For Safety



Smart Logic Controller Sturdy



10 mm Tempered Glass Adds Aesthetics

Product Range



Pro



Prime



Advanced Design



Excellent Finish



Hieroglyphic Symbols

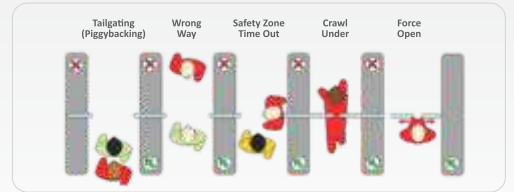

User Safety

Options

- Single lane or multiple lane setups.
- Normally open or normally closed working mode.
- Top cover equipped with artificial marble or stainless steel several color of arms optional adaptation for integration of a proximity card reader under the top cover.
- Pedestal for mounting of external card readers, biometric or other authorization systems.



Single Core



Dual Core

Technical Specification

Sliding Barrier Single/Dual Unit		
Model	Pro	Prime
Dimension (LxWxH) mm	1400x350x980	1500x300x980
Passage width	550 mm	550 mm
Power supply	230 VAC	230 VAC
Protection rating	IP 55	IP 55
Arm type	Acrylic	Tempered glass
Operating time	0.2 sec	0.2 sec
Throughput rate p/m	30-35	30-35
Motor	DC brushless motor	Fully automatic servo motor
Top Frame	black artificial marble at access portion	White artificial marble at top
Access control integration provision	YES	YES
LED indications	NO	LED indication arrow light bar(optional)
	Top cover with multi color indication LED on front edges	Top cover with multi color indication LED on front edges
Arm Height	Standard	Full height)
Wide lane	NO	NO (Full height)

Functions & Features

- Infrared anti-pinch: Installed multiple pairs of infrared detectors in the area close to the movement of the wing (anti-pinch area).
- The access direction of the turnstile for both entries and exits is determined by internal sensors.
- Extra-wide device body.
- Smooth and quiet operation.
- Durable motor.
- All-in-one solution with RFID and fingerprint access control.
- Tailgating, wrong way detection.
- Easy installation and maintenance.

ACCESSORIES

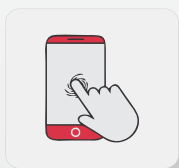

Smart Phone Based Access

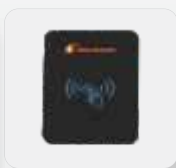

RFID Reader



Biometric Access Control

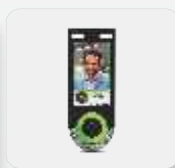

Face Recognition

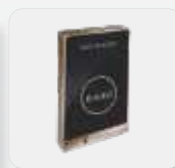

QR Code Reader

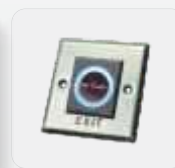

Touchless Sensor

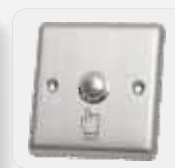

Push Button



Driven By Innovation

Smart Entrance Solutions

The background of the page is a photograph of two tripod turnstiles in a well-lit indoor setting. The turnstiles are made of a light-colored metal, possibly aluminum or stainless steel, and have three legs that form a tripod shape. Each turnstile has a horizontal bar across the top and a green arrow pointing downwards on its side, indicating the direction of travel. The floor is a light-colored, textured material, and there are some steps visible in the background. A large, diagonal blue graphic element cuts across the bottom right of the image, partially overlapping the turnstiles and the text.

Tripod Turnstile

Tripod Turnstile

DRIVEN BY INNOVATION

Tripod Turnstiles can be used for access control to make secure access for Reception Staff at Entrances to Offices and Administrative Buildings, Industrial Premises, Banks, Public Authorities and Many Sports Facilities. They are quick, reliable and easy to use. Avians offers wide range of Tripod Turnstiles. Our designed and tested control technology regulates the flow of people with ease, even at the busiest times of day.

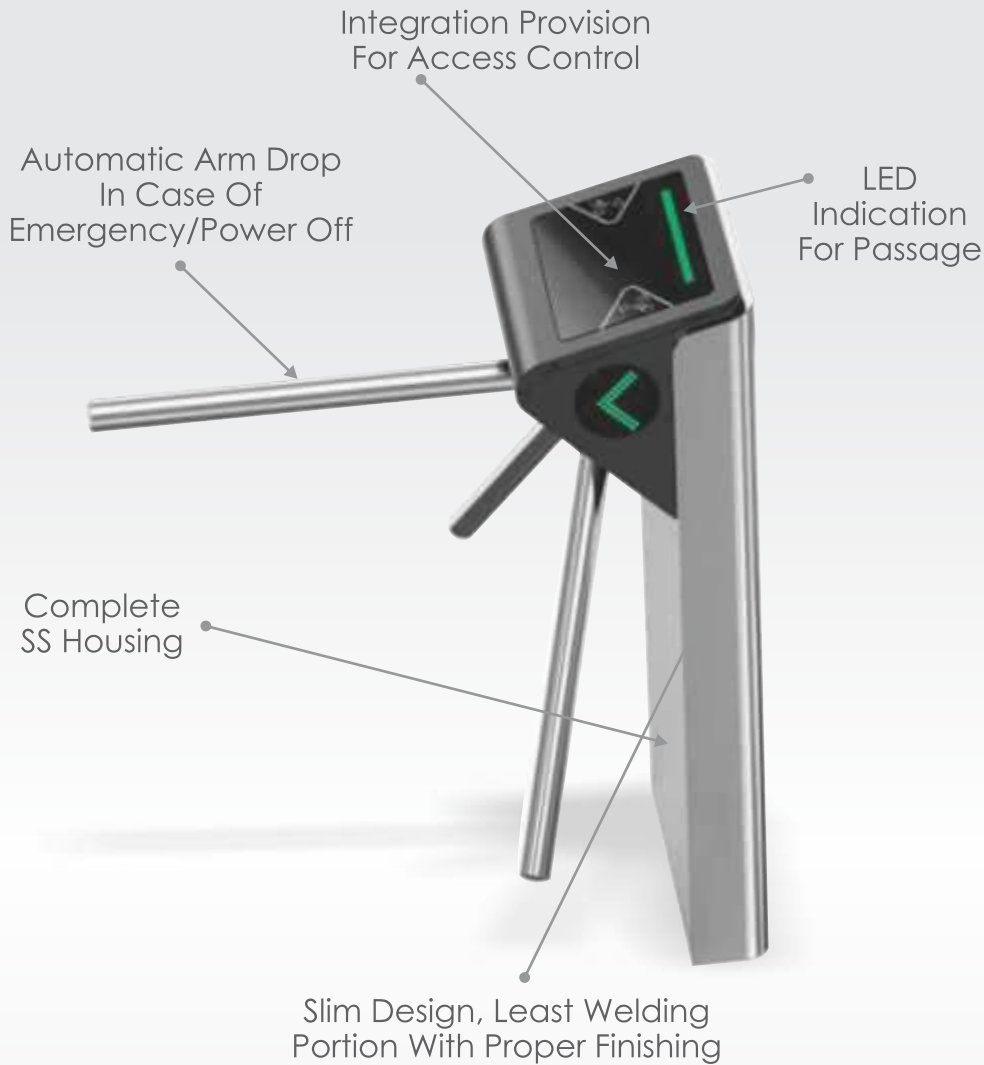

Bi-directions



Fast Transit



Lower Power Consumption



Alarm System



Communication Mode RS 485

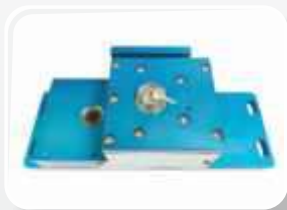

Sturdy Machine Core



Anti Panic Barrier Arm



Main Control Board



Advance Motorised Control

Product Range

PILLAR TYPE



Pro



Pro+



Prime

BRIDGE TYPE



Pro



Pro+



Prime



DUAL CORE TRIPOD TURNSTILE TO SAVE THE SPACE



Options

- Single lane or multiple lane setups.
- Normally open or normally closed working mode.
- Pedestal for mounting of external card readers, biometric or other authorization systems.
- Motorised option available.
- Can integrate with ESD system.



Single Core



Dual Core

Technical Specifications						
Model	Pillar Type			Bridge Type		
	Pro	Pro+	Prime	Pro	Pro+	Prime
Dimension excluding bar (LXWXH) mm	480x280x960	480x280x980	370x283x980	1200x280x960	1200x280x980	840x300x960
Passage width	550	550	550-600	550	550	550-600
Material thickness	1.0 mm SS304	1.2 mm SS304	1.2 mm SS304	1.0 mm SS304	1.2 mm SS304	1.2 mm SS304
Power supply	230 VAC, 35W	230 VAC, 35W	230 VAC, 50W	230 VAC, 35W	230 VAC, 50W	230 VAC, 50W
Protection rating	IP 55	IP 55	IP 55	IP 55	IP 55	IP 55
Operating time	0.2 Sec	0.2 Sec	0.2 Sec	0.2 Sec	0.2 Sec	0.2 Sec
Throughput rate p/m	30-35	30-35	30-35	30-35	30-35	30-35
Machine core	Basic	Standard	Motorised advanced machine core	Basic	Standard	Advanced machine core
Body structure	Standard design	Elegant design	Premium elegant & slim design	Standard design	Elegant design	Premium elegant design
Operation	Smooth operation	Smooth operation	Smooth operation with premium feel	Smooth operation	Smooth operation	Smooth operation with premium feel
Access control integration	Smart integration of single access control accessories	Smart integration of multiple access control accessories	Smart integration of single access control accessories	Smart integration of single access control accessories	Smart integration of multiple access control accessories	Smart integration of single access control accessories
LED indications	LED indication arrows	Attractive LED lights	Arrow LED with indication	LED indication arrows	Attractive LED lights	Arrow LED with indication
Dual core unit option	Yes	No	No	Yes	No	No
Motorised option	Optional	Optional	Optional	Optional	Optional	Optional

Functions & Features

- Bi-direction, can set to one direction & one for free.
- Direction indication LED lights on the barrier indicate whether the directions allowed or not .
- Electro mechanical operation. Motorised option available.
- Semi-auto mode: After reading card the passenger pushes the arm by to rotate it at 120 degree.
- Only one person will pass with one card.
- Integration with various access control system like, biometric, card, QR/barcode & face recognition terminals.
- With standard fire alarm input interface, when received the fire alarm signal arms will drop automatically to set the passage free.

ACCESSORIES

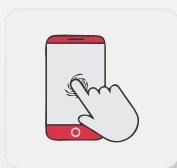

Smart Phone Based Access

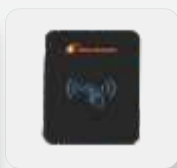

RFID Reader



Biometric Access Control



Face Recognition

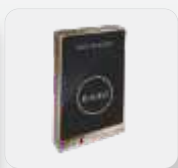

QR Code Reader



Touchless Sensor



Push Button

Single Drop Arm Turnstile

The newly designed drop arm turnstile is another superior product which has slim cabinet design, attractive brushed finish stainless steel cabinet. The compact footprint of this turnstile makes it an excellent choice for installations with limited floor space. Another advantage of the turnstile is that both standard and handicapped passage width configurations have the same cabinet dimensions.

Drop arm function turnstile is mainly installed in entrance and exit of shopping mall which has a large flow rate; it is most popular in supermarket. Can be widely used in the station, factories, office building, hotel, clubs, intelligent community, enterprises and institution that need intelligent access management.

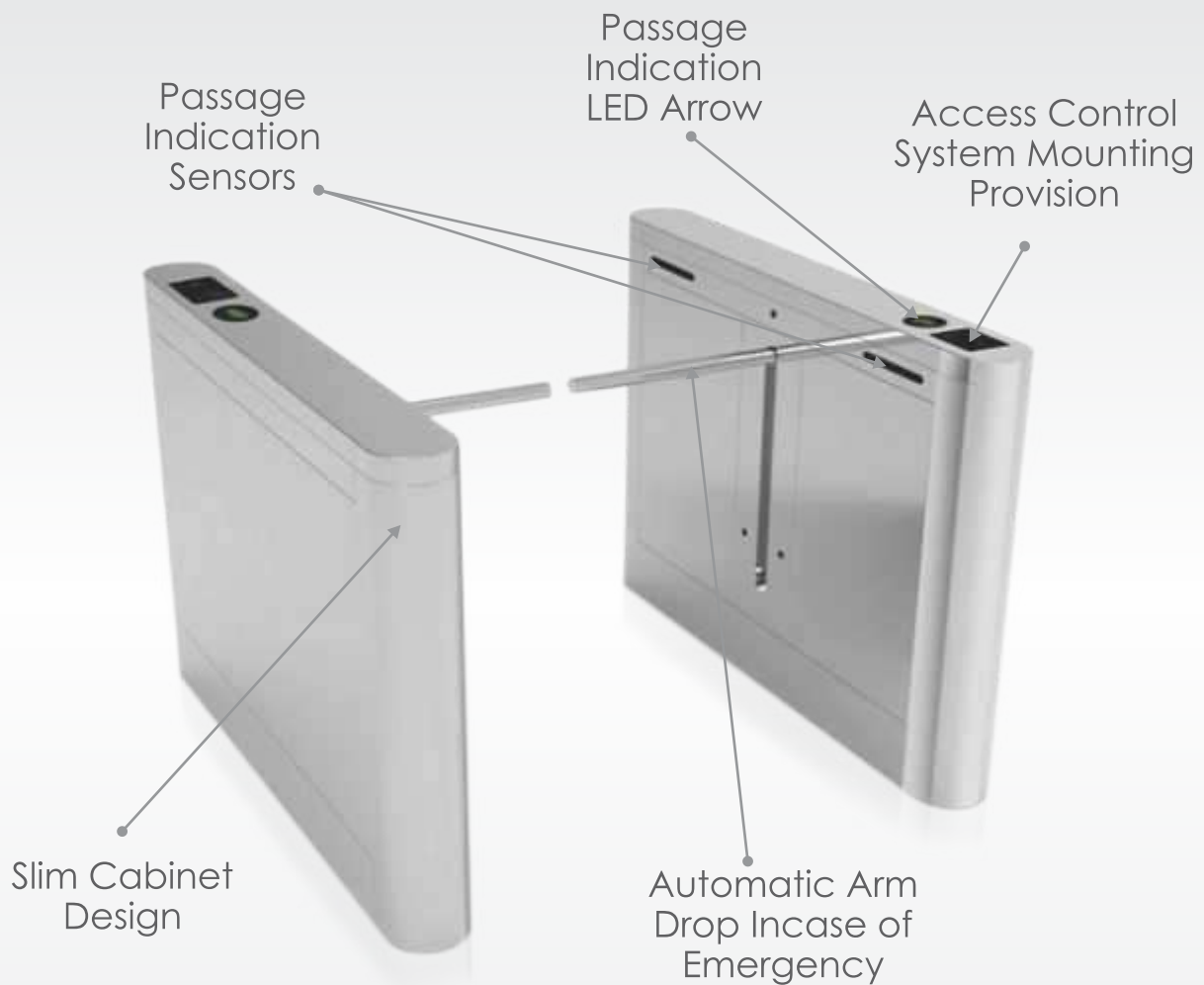

Features

- Quick, precise and reliable arm movement – no need for constant adjustments.
- Supports rapid throughput.
- Equipped with the dry contact signal input interface, compatible with all kinds of access controllers.
- It will alarm when illegal entry/exit, followed by people, passed overtime, damaged for equipment.
- Drop arms retract quickly and smoothly to allow passage.
- Bidirectional operational control.
- Provides years of trouble free operation.
- Due to motorised operation completely touchless entry/exit.

Product Range



Technical Specifications	
Single Drop Arm Turnstile	
Model	Pro
Dimension (LxWxH) mm	1200 x 280 x 980
Passage width	600 mm
Material thickness	1.2 mm thick S304
Power supply	230 VAC
Arm type	Metallic
Operating time	0.2 sec
Protection rating	IP55
Throughput rate p/m	20-25
Motor	DC Motor
Body Structure	Sleek design
Access Control Integration provision	YES
LED indications	LED indication arrows
Wide lane	Optional



Driven By Innovation

Smart Entrance Solutions

A photograph of a full-height turnstile in a modern building entrance. The turnstile is made of metal and has a glass door. The background shows a bright, open space with large windows and some greenery. A blue diagonal graphic element is overlaid on the right side of the image.

Full Height Turnstile

Full Height Turnstile

DRIVEN BY INNOVATION

Single Lane & Dual Lane Full Height Turnstile gates are typically used for Pedestrian Movement in Factories, Office, Amusement Parks, Museums, Stadium, Sports Arena etc. for efficiency & a higher degree of security control and managing movement of pedestrians.

These Full Height Turnstiles are offered with electro mechanical unit for the 3 X 120°/4 X 90° Indexing arm movement with an encoder for position sensing. The Turnstile is aesthetically & ergonomically designed to locate varied access control systems that may be integrated in a discreet yet easy to access manner.

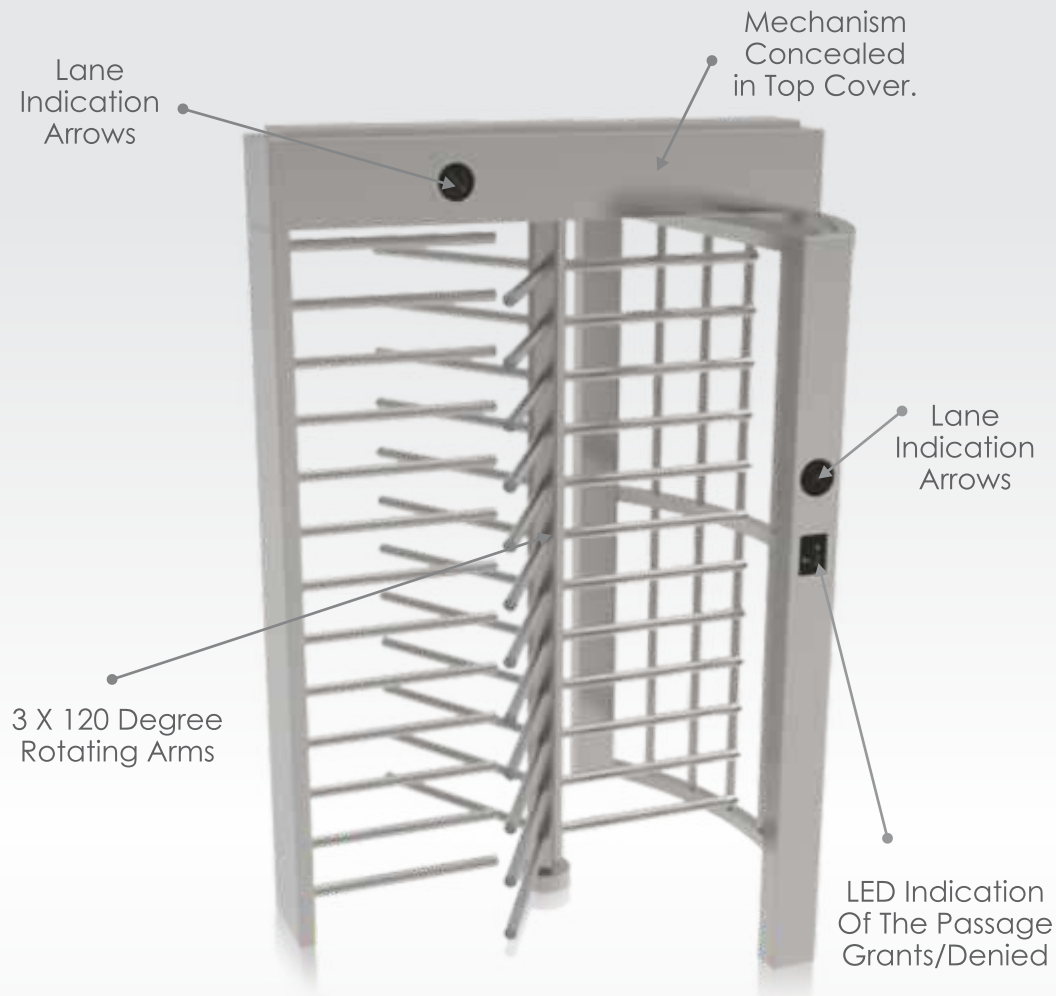

Bi-directions



90-120 Degree



IP55



Colour Option



Material Option



Key



Manual Release Key For Manual Operation



Modular Electro Mechanical Control Unit



Precision Machine Core



Pre Programmed Control Unit

Product Range



Pro-Single Lane



Pro-Dual Lane



Half Height



Pro+ - Single Lane



Pro+ - Dual Lane



ELECTROMECHANICAL



BIDIRECTIONAL



INDOOR/OUTDOOR

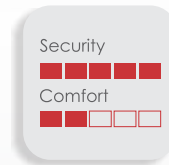

SECURITY/COMFORT



30 PASSAGES/MIN

Options

- Single lane or multiple lane setups.
- Normally open or normally closed working mode.
- Pedestal for mounting of external card readers, biometric or other authorization systems.

Technical Specifications Single/Dual Unit			
Model	Pro	Pro+	Half Height Turnstile
Single lane	1630x1300x2310 mm	1630x1500x2310 mm	1400x1250x1100 mm
Dual lane	2100x1500x2310 mm	2400x1500x2310 mm	NA
Passage width	550 mm	650 mm	550 mm
Arm Rotation	90(4 arm)/120 degree(3 arm)	90(4 arm)/120 degree(3 arm)	90(4 arm)/120 degree(3 arm)
Material thickness	1.5 mm thk SS304	1.5 mm thk SS304	1.5 mm thk SS304
Power supply	230 VAC, 40W	230 VAC, 40W	230 VAC, 40W
Protection rating	IP55	IP55	IP55
Operating time	0.2 sec	0.2 sec	0.2 sec
Throughput rate p/m	30-35	30-35	20-25
Machine core	Standard	Advance	Standard
Access control integration provision	YES	YES	YES
LED indications	LED indication arrows	LED indication arrows	LED indication arrows
Color option	YES	YES	YES
Standard material	Complete SS304	Complete SS304	Complete SS304
Optional material	MS side frames, SS 304 rotar	MS side frames, SS 304 rotar	MS side frames, SS 304 rotar
	Complete MS	Complete MS	Complete MS

Functions & Features

- Bi-direction, can set to one direction & one for free.
- Rotor : 4x90 degree OR 3x120 degree.
- Direction indication LED lights on the barrier to tell you whether the direction go or not.
- Semi-auto mode: After reading card the passenger pushes the arm by hand until he goes through the barriers and the arm arrives in home position.
- Only one person will pass with one card.
- Integration with various access control system like, biometric, card, QR/barcode & face recognition terminals.
- Housing material: MS powder coated or stainless steel grade 304, with stainless steel rotor and bars.
- Installed in Indoor Or Outdoor with canopy.
- Four cage type & economical versions are available.
- Micro-controller based logic control board.
- 100% modular system: composition according customers' desires and expandable at any moment.
- Optional damping system guarantees smooth and gradual movements. Damping is continuous and unaffected by temperature changes.
- Color options available.

ACCESSORIES

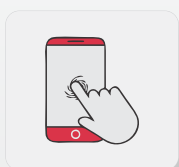

Smart Phone Based Access

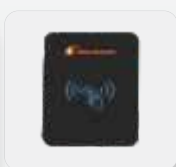

RFID Reader



Biometric Access Control

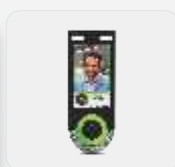

Face Recognition

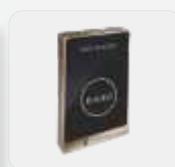

QR Code Reader

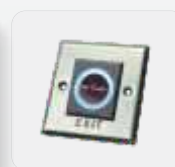

Touchless Sensor

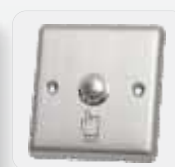

Push Button



Driven By Innovation
Smart Entrance Solutions



Boom Barrier

Boom Barrier

DRIVEN BY INNOVATION

Boom Barrier is designed for a range of large opening up to 6m. As a manufacturer we have experience on designing, fabricating, installing Boom Barriers. The result is a superior Boom Barrier, giving long service life and peace of mind. Quality is our top priority, so we vigorously test our Boom Barriers to ensure long service life in the field.

Thanks to excellent craft, nice welding, galvanized and powder coated surface finish, quiet and smooth operation, Boom Barrier can bring perfect usage experience to customers.

LED Indication
Arrow To Show
Boom Position

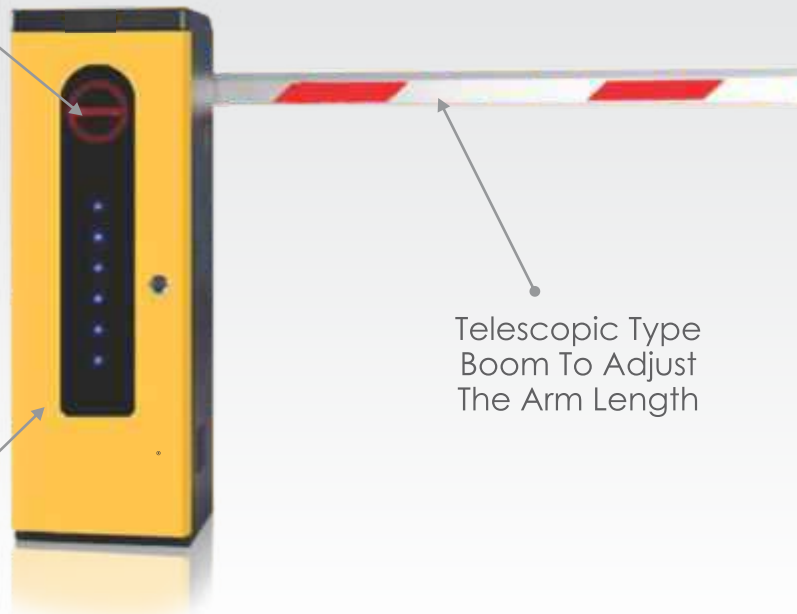

User Friendly
Design



24X7 Operation



Superior Capacity



P55/IP 65 Option
Available



100% Duty Cycle



Colour Option
On Bulk Order



Straight Arm
With LED Optional



Handle For
Manual Release



Heavy Duty
Motor



Pre Programmed
Control Unit

Product Range

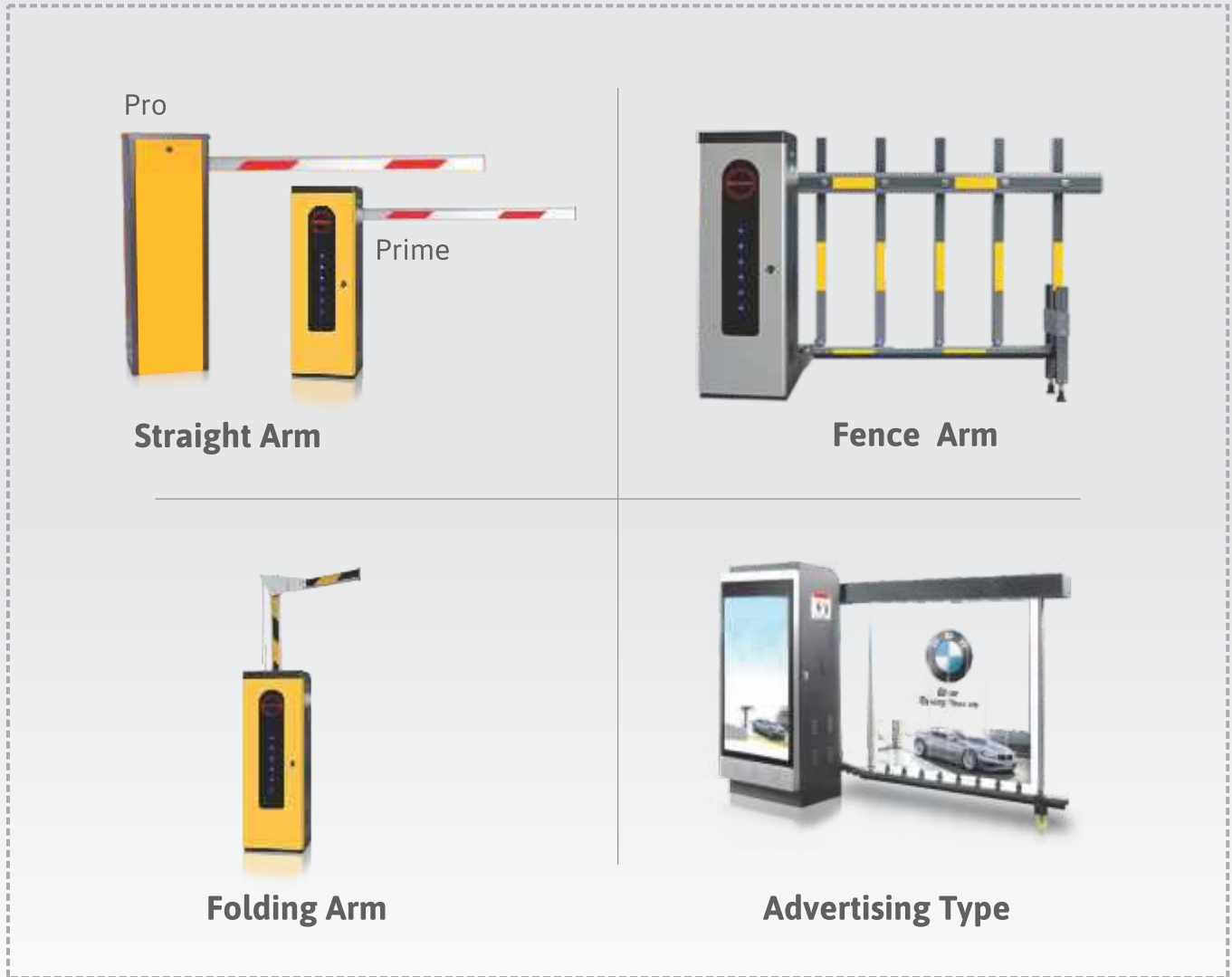

Functions & Features

- These are designed to deliver maximum performance 24/7 no breaks.
- Avians is respecting the individuality of its customers. Therefore boom shape and left-hand or right-hand assembly according to customer's request are available, customize color options available for bulk quantity order.
- All automatic barriers are designed with maximum safety in mind. It has auto reverse function, safety photocells kit, swing away arm mechanism in straight arm boom barrier (optional), flashing light, boom LED lights (optional).
- Boom with high-visibility striping.
- Powerful drive unit.
- Smooth boom movement with automatic slowdown.
- Comes with obstacle detection system (safety photocell) which makes barrier to move upwards if any obstacle is detected.
- Android app for seamless opening to smart phone.

Technical Specifications

Boom Barriers

Boom Barrier Model	H-Series	E-Series
Arm length	Straight - up to 6m	Straight - up to 6m
	Fence - up to 4.5m	Optional
	Folding - up to 5m	Optional
	Advertising - up to 3.7m	NA
Housing dimension	280L x 355W x 1050H mm	240L x 345W x 1020H mm
Material	Metal casing with powder coating	Metal casing with powder coating
Design	Modular	Standard
Motor	AC brushless /100W	AC brushless /100W
	DC brushless/120W	DC brushless/120W
Input power supply	230 VAC, 50 HZ	230 VAC, 50 HZ
Arm direction	Fixed	Fixed
Arm profile	Octagonal	Octagonal
IP rating	IP55/IP65 (Optional)	IP55/IP65 (Optional)
Emergency operation	Manual	Manual
Swing away arm	Option available	Option available
Certificate	CE, NABL	CE, NABL
Working environment	Indoor, Outdoor	Indoor, Outdoor
LED on boom	Optional	Optional
LED on housing	Standard	Optional
Duty cycle	100%	100%
Motor rotation speed	1500 rpm	1500 rpm
Operating time	Up to 3,6 sec	Up to 3,6 sec
Stroke control	AC-limit switch	AC-limit switch
	DC- Encoder	DC- Encoder

ACCESSORIES

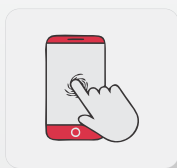

Smart Phone Based Access



Boom Stand Fixed & Mobile Support

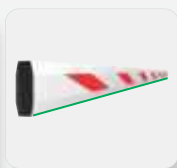

LED On Boom Arm

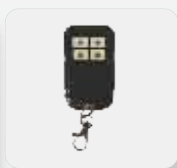

Remote Controller



Safety Photocell



UHF Reader



Push Button

Special Application Boom Barrier

DRIVEN BY INNOVATION

Toll Plaza Boom Barrier

Avians Toll Plaza Boom Barriers are maintained short opening and closing time. It is also considered to avoid boom bouncing in the end positions. Hence, makes the opening-closing operation smoother. In the event of a power failure, it can still be moved easily by hand (optional). A built in spring mechanism provides a precise counterbalance for the barrier boom. Model has got specially designed safety Boom holder as we consider heavy use at toll plaza application. It provides maximizes boom life. Product is designed keeping in mind with the Indian context Weather conditions, rough use, power fluctuations. Thanks to heavy duty & rigid constructions.

Crash Rated Boom Barrier

Avians Crash Rated Boom Barrier has been crash tested by wherein barrier stopped a 7.2 ton truck @ 48 km/h. It is designed to completely close an entrance line to a facility and bring vehicles to a rapid halt; our barriers are of choice for Military, Government & Commercial installations around the world.

The unique design has been proven in the field against threats including terror and theft. All parts of barriers are treated for pre-finished and then given a double layer of painting to prevent rust. Smart control can be integrated with other safety equipments.



Toll Plaza Application



Crash Rated
Boom Barrier



High Efficiency
Servo Motor



Smart Digital
Control Panel



Advanced Hydraulic
Power-Pack



K4 Rated
(6.8 Ton Truck
Impacted at 48 km/h)

Toll Plaza Boom Barrier Functions & Features

- High Speed Boom Barrier System. (0.6-0.9 Second Operation)
- Can be used in ETC (electronic toll collection) Lane.
- Specially designed for Toll Industry.
- Plug & Play System, ready to connect to any Lane Controller System.
- Safety features for human and vehicle safe technical data.

Crash Rated Boom Barrier Functions & Features

- Electro hydraulically operated with internal locking feature circuit controller for auto off in fully raised & lowered position with limit switches.
- All parts of the barriers are manufactured keeping in mind the corrosive nature of climate and are corrosion proof.
- Robust power transmission.
- Opening closing speed can be adjusted.
- The barrier can easily be operated manually in times of power failure.
- Hydraulic power pack can be installed within the barrier body or can be separately installed in case of space constraint is there.
- Safety accessories against human traffic & vehicles.
- Manual operating override facility.

Technical Specification

Toll Plaza Boom Barrier	
Dimension of housing arm	342 x 312 x 960 mm
Length	2.5 to 3 mtr
Housing	Galvanized steel with powder coated
Drive	Servo motor
Swing away arm option arm	Available
Direction	Can be change left or right (optional)
Power supply	230 VAC, 100W
Output torque	120 N.M
Motor no-load speed	3000 r/min
Operating temperature	-20 to +70°C
Life cycle	10 millions
Open/Close time for 2.5 mtr	0.6 sec
Open/Close time for 3 mtr	0.9 sec

Crash Rated Boom Barrier	
Material	High tensile carbon steel
Barrier type	Crash boom barrier
Mechanism	Electro-hydraulic
Dimension	3-7 m
Operating temperature	-10 to +60 °C
Power supply	3 phase
Speed	6-8 sec
Operating option	Push button
Protection class	IP66
Impact load	656 Kilo joules
Crash rated	K4 rated, 7.2 ton truck impact@48kmph
Control panel	Smart control panel for various accessories integration.

ACCESSORIES

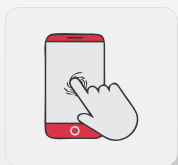

Smart Phone Based Access

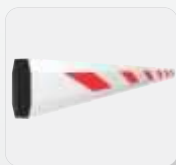

LED On Boom Arm



Remote Controller

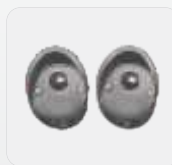

Safety Photocell

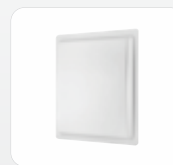

UHF Reader

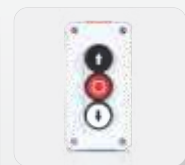

Push Button

Metro, Railway & BRT Stations



Airports



Sports Center, Public & Government Utilities Spaces



Corporate, IT and Commercial Spaces



Schools/Universities



Industrial Area



Retail



Amusement Parks



Residential/Commercial/Industrial Entrances



Vehicle Parking Lots & Exhibition Centers



Factories & Hotel



Specially Disabled



Other VAS Product Range



Automatic Bollard

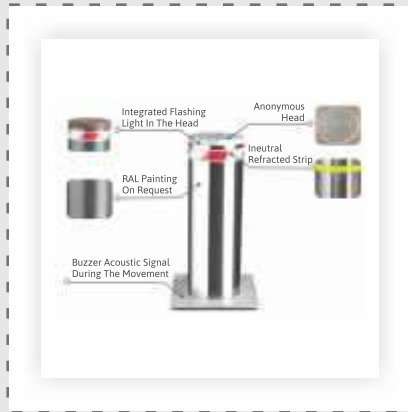

Crash Rated Bollard



Fixed Bollard



Manual Bollard



Road Blocker

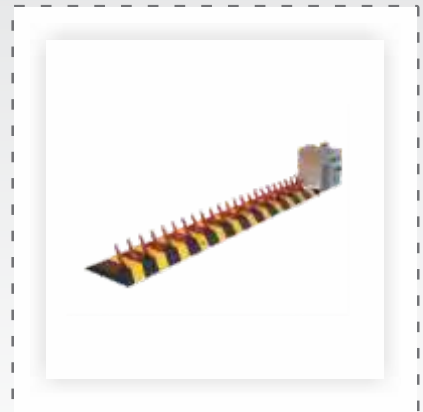

Spike/Tyre Killer



Crash Rated Boom Barrier

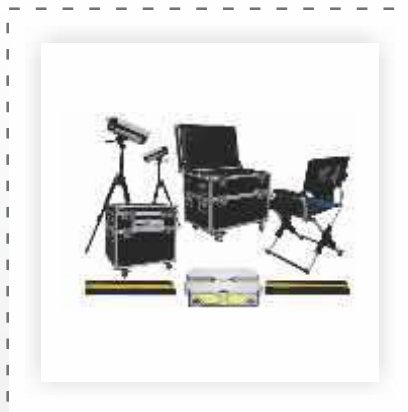

Under Vehicle Scanning System



Automatic Number Plate Recognition

FEW OF OUR PRESTIGIOUS CLIENT

- Hindustan Petroleum Corporation of India
- Tetra Pack
- Macleods Pharma
- Sunpower Ltd.
- Finolex Ind. Ltd.
- CRPF Camp
- Tata Mettalics
- MHA
- Saibaba Temple Shirdi
- Sandvik Asia
- Amphenol
- Vidharbha Cargo
- BOSCH Ltd.
- TATA Group
- Hindware
- Pavillion Hotel
- LG Electronics
- ITC
- Haier
- Unichem
- HUL
- Fiat
- Volkswagen India
- Sassan Coal mine
- Hyosung India
- Beoing
- Hero MotoCorp
- MRF Ltd.
- Daimler India
- Cummins
- Hindustan-CocaCola
- Wipro
- JSW Steel Coated Products Ltd.
- Jaguar Group
- Amazon
- Syntel
- JBM
- Asians Paints
- Kansai Nerolac
- Kajaria Tiles
- P & G
- Ikea
- Hiranandani One
- United Breweries

Avians have more than 1000+ Clients & have Executed Projects in Entrance Automation for over 4 decades and hold a strong position in the entrance automation segment.

AVIANS ADVANTAGE

- 40 Years Legacy of the Brand.
- Wide Product Range of Physical Access Control Solutions.
- Strong Pan India Network for Sales and Service Support.
- Strong Base of Satisfied Customers.
- Continuous Technical Advancement for Product Innovation.
- Assurance to Deliver Quality Class Product.
- International Quality Certifications (CE).
- Company is an ISO 9001, ISO 14001 and ISO 45001 certified.
- Customised Solution for Restrictive Access.
- Aesthetics and Super Finish available in SS302, SS304 & SS316.
- All Product Certified to IP 55 Standards.
- Best in Class Infrastructure for manufacturing, quality & delivery.
- State of the Art 280000 Sq ft of Modern Factory and Corporate Office at Pune.
- Inhouse R&D Unit for Product Testing and Validation.
- Best Talent Resource in the Industry.

PHILOSOPHY



Customer Focus



Quality



Innovation



Product Consultancy



Promptness

Our National Presence

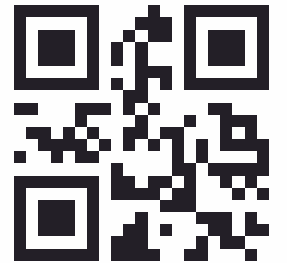
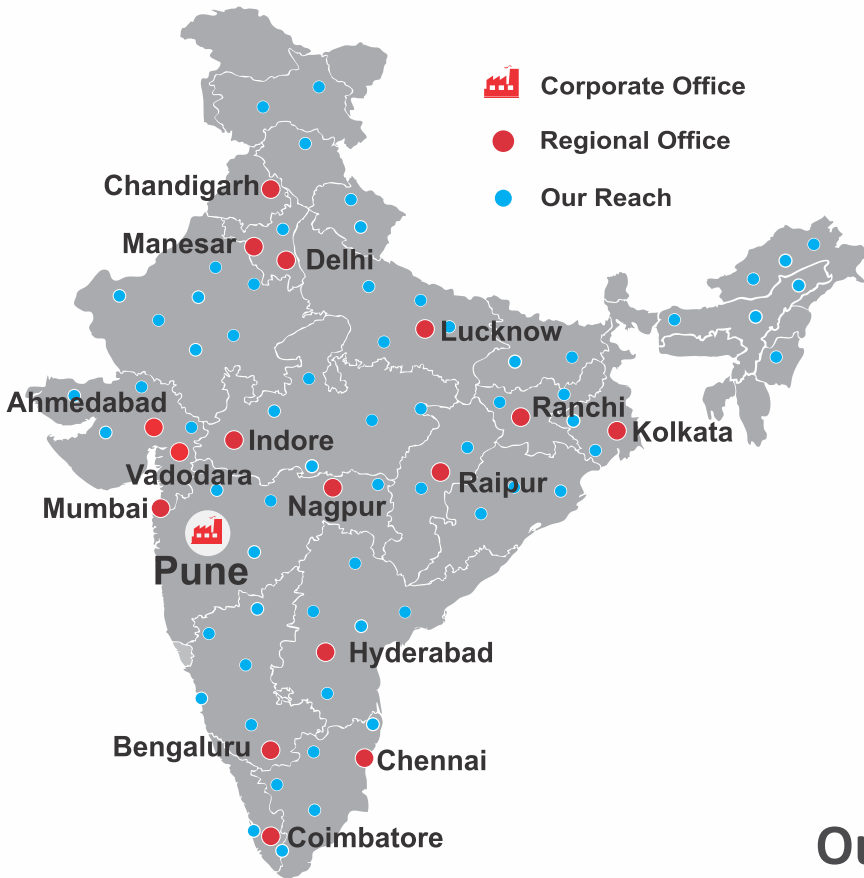

Our Global Presence

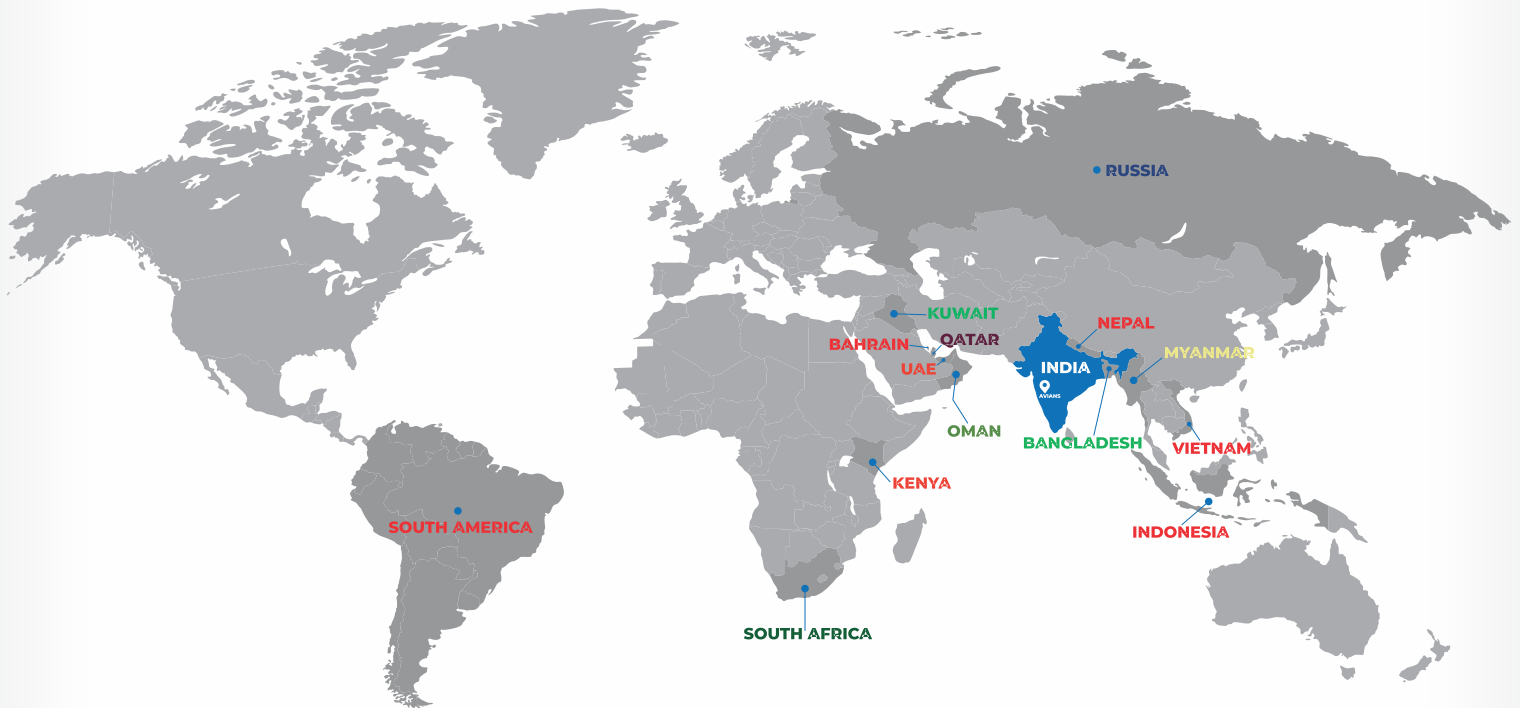

FOR SALES ENQUIRY +91 20 71 400 600 +91 8390 300 400 sales@avians.co.in www.avians.co.in

Avians Innovations Technology Pvt. Ltd.

Corporate Office: Gat No. 60-61, Dehu-Moshi Road, Chikhali, Pune-411062, MH, India.

Follow Us On:



AN ISO 9001-14001-45001 Certified Company